



# ARLINGTON

## VIRGINIA

**Inspection Services Division**

# **Typical Deck Details**

**Based on the 2006 Virginia Uniform Statewide Building Code**

---

## **COVENANTS AND DEED RESTRICTIONS**

Many of the subdivisions and developments in Arlington County have private deed restrictions and covenants regulating the construction of decks beyond the limitations contained in the County Ordinances. These amount to contractual agreements between property owners and are enforceable through civil actions. **The County does not enforce covenants and deed restrictions and is not always aware of their existence.** Should you have questions about your development's restrictions you may obtain information from your homeowner's association or civic association.

### **WHAT PERMITS ARE REQUIRED**

A building permit is required for all decks.

For decks that include hot tubs, spas, etc., electrical, mechanical and/or plumbing permits are also required.

### **WHERE TO APPLY FOR PERMITS**

Application for permits should be made in person at the Inspection Services Division Office,  
2100 Clarendon Blvd. 10<sup>th</sup> floor  
Suite 1000, Arlington Virginia, 22201  
Tel: 703-228-3800 Fax: 703-228-7046  
Monday through Friday, 8:00am to 5:00pm

### **WHO CAN APPLY FOR PERMITS**

If a contractor is to perform the work, Arlington County strongly recommends that the contractor be the party to secure the permit. In this way, the County will be in a better position to assist the homeowner to gain compliance with codes if the work is defective. However, the property owner may secure the permit(s).

### **WHAT IS THE COST OF PERMITS**

Building permit costs for the construction of a deck are calculated by the square footage based on the inspectable area; authorized by the Arlington County Inspections Services fee schedule, as approved by the Board of Supervisors.

After the building permit is issued, separate fees will be charged if other permits are required based on actual equipment installed on the deck. Examples of equipment requiring additional permits include, but are not limited to, hot tubs, spas, gas grills, etc.

## **WHAT IS REQUIRED TO OBTAIN THE PERMIT**

### **PERMIT APPLICATION**

A completed and signed Building Permit Application

### **STUCTURAL PLANS**

Provide two copies of a structural plan

The plan must be a scaled drawing showing the dimensions of your deck. The minimum acceptable scale is ¼" to 1' and must include the following information:

- framing plan showing the size of all posts, joists and beams;
- handrail and guardrail details;
- stair details, if applicable
- elevations, front, side and rear with attachment details (such as attachment to house, joist to beams, rails to posts, etc); and
- footing details including location, size and depth

Drawing prepared on sheets smaller than 11"x17" for will not be accepted.

Please note that railings are for any structure that will be more than 30" from grade level. The railings must be at least 36" high and have intermediate or ornamental closures that will not allow passage of an object 4 inches or more in diameter.

Some building material supply stores have acceptable deck plans for sale to the public. You may use these to obtain the information listed above.

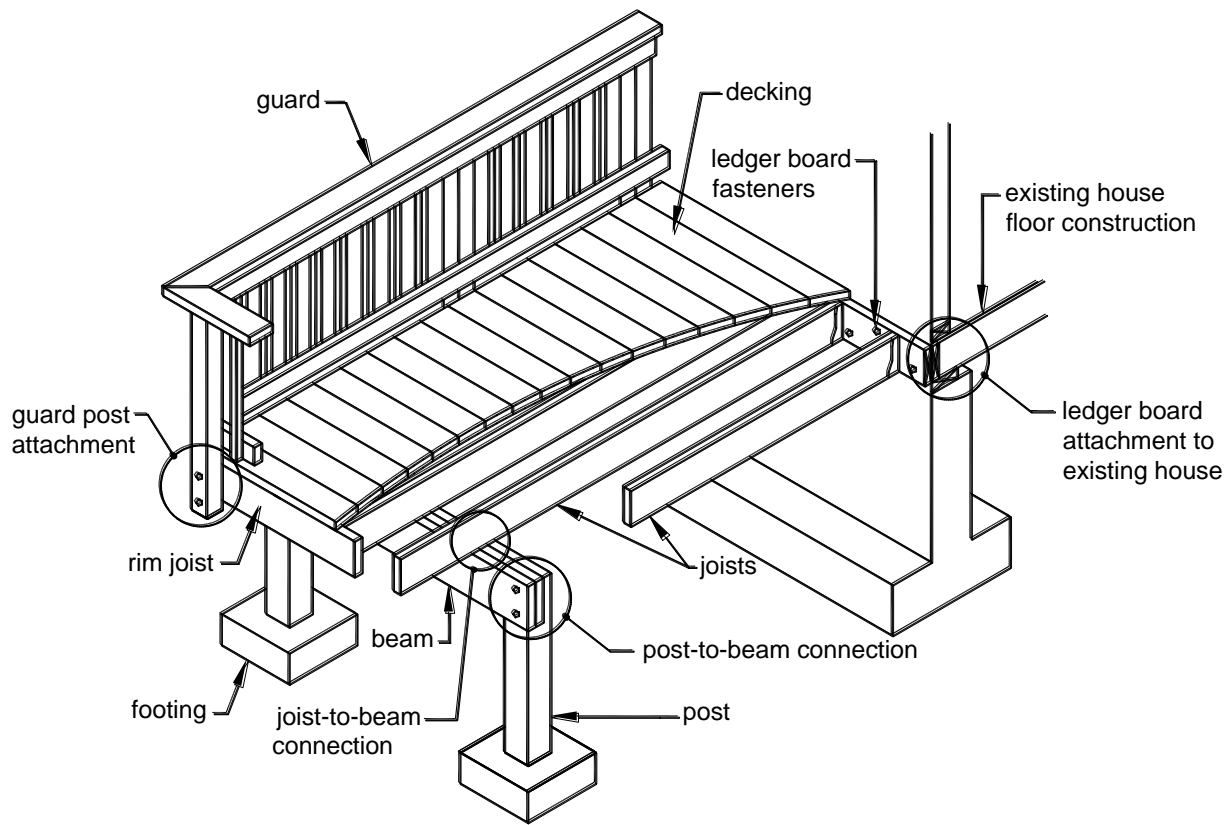
A copy of the Arlington County deck details are attached for homeowner and contractor use. The typical deck details may be used to supply some of the required plan information that applies to conventional open decks.

For decks with roofs, screened porches, hot tubs, or any additional loads, additional plans and details are required.

### **PLATS**

Provide three copies of your House Location Plat

If you do not have a copy of the House Location Plat, you can contact the Zoning Administration Office,  
2100 Clarendon Blvd. 10<sup>th</sup> floor  
Suite 1000, Arlington Virginia, 22201  
Tel: 703-228-3883 Fax: 703-228-3896  
Monday through Friday, 8:00am to 5:00pm



## CONTENTS

General Notes

Decking Requirements

Joist Size

Beam Size and Assembly Requirements

Deck Framing Plan

Joist-to-Beam Connection

Joist Hangers

Post Requirements

Rim Joist Requirements

Footings

Ledger Attachment Requirements

Prohibited Ledger Attachments

Ledger Board Fasteners

Framing at Chimney or Bay Window

Free-Standing Decks

Lateral Support of Free-Standing Decks

Guard Requirements

Guard Post Attachments

Stair Requirements

## GENERAL NOTES

1. Unless noted otherwise in within these details, all lumber shall be southern pine, grade #2 or better and shall be pressure treated ACQ, CA-B or CuN-W in accordance with American Wood-Preservers' Association standards. All lumber in contact with the ground shall be rated as "ground-contact." **Please note: not all treated lumber is rated for ground contact.**
2. All nails shall be spiral or annular grooved.
3. All screws and nails shall be hot-dipped galvanized or stainless steel.
4. All hardware (joist hangers, cast-in-place post anchors, mechanical fasteners, etc.) shall be galvanized with 1.85 oz/sf of zinc (G-185 coating) or shall be stainless steel. Look for products such as "Zmax" from Simpson Strong-Tie or "Triple Zinc" from USP.
5. Decks constructed in accordance with these details are not approved for future hot tub installations.
6. Decks shall not be attached to house overhangs, bay windows, brick veneers, or chimneys.
7. When an existing house wall which encloses any portion of a deck contains a window, individual panes must be safety glazed if the bottom edge is less than 18" above the deck floor, the top edge is greater than 36" above the deck floor AND the total pane area is greater than 9 sf. For additional safety glazing requirements, see Sheet 24.
8. Conditions which do not meet these details will require a plan submission.
9. Inspections:
  - A footing, framing, and final inspection are required on all decks.
  - Footing inspections are required PRIOR to the placement of concrete.
  - At the time of the footing inspection, the ledger board must be attached to the existing house. Adequacy of connections will be verified by county inspectors. If a ladder is required to access the ledger board, one must be provided.
  - Framing and final inspections may be combined if all portions of the deck framing and mechanical attachments are at least 48" above grade.
  - Inspections are required by law. Failure to receive any and all inspections can result in the issuance of violations which may lead to legal proceedings.
10. It is the responsibility of the permit holder or the permit holder's representatives to notify the County when the stages of construction are reached that require an inspection. Inspection requests may be made using one of the methods listed below; please have your permit number available when scheduling an inspection. Requests made prior to 7:59 p.m. on automated systems can be scheduled for the next business day.
  - Inspection Services Division: **703-228-3800**, 8 a.m. to 5:00 p.m., Monday – Friday.
  - Integrated Voice Response System (IVR): **703-228-3700**
  - Inspections Services Online Permitting: <http://www.velocityhall.com/> .
11. Please note the following inspections are required for all decks: footing (102), framing (108) and final (118).
12. Decks shall not be used or occupied until a final inspection approval is obtained.

## **DECKING REQUIREMENTS**

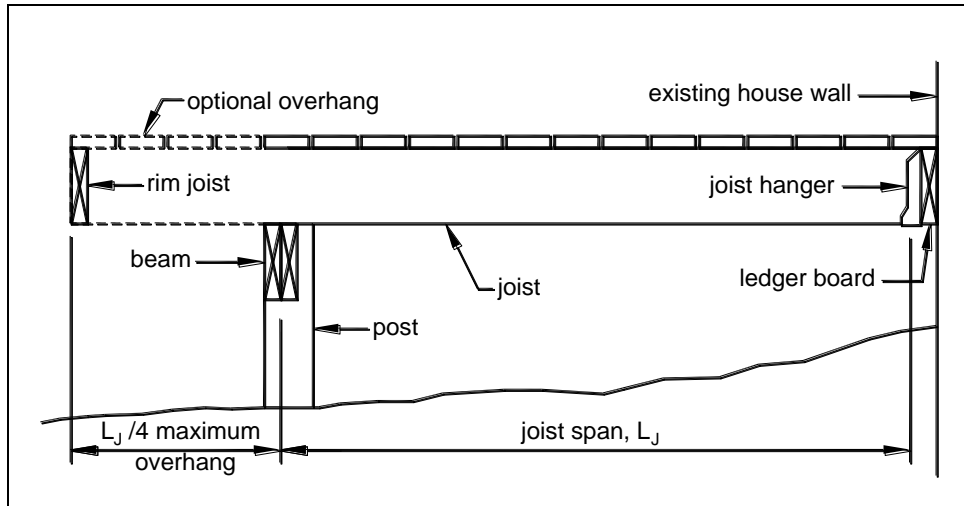
All decking material shall be composed of 2x6 or  $\frac{5}{4}$  (five-quarter) board. Attach decking to each joist with a minimum of (2) 8d nails or (2) #8 screws. Space decking with a  $\frac{1}{8}$ " gap between each board. See FIGURE 11 for decking connection requirements at the rim joist. Decking may be placed from an angle perpendicular to the joists to an angle of 45 degrees to the joists.

Decking composed of foreign lumber, plastic or manufactured materials may be substituted only when the product has an approved evaluation report from an accredited evaluation service. For a list of approved products, go to the website below.

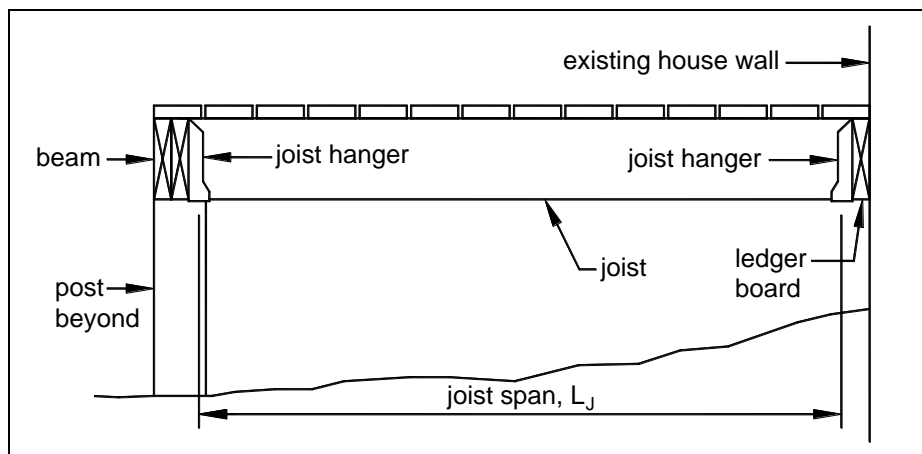
The evaluation report must be on the jobsite and available to the inspector during the inspection process. Installation and span lengths of the substituted material must be in strict conformance with the evaluation report and the manufacturer's instructions. All decking products must be capable of supporting a live load of 40 pounds per square feet.

## JOIST SIZE

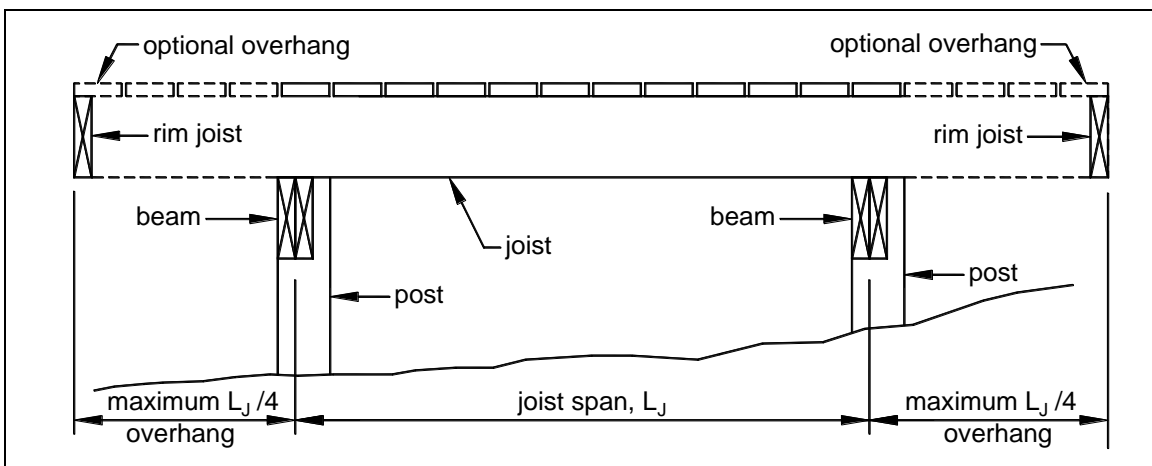
The span of a joist is measured from the centerline of bearing at one end of the joist to the centerline of bearing at the other and does not include the length of the overhangs. Joists may overhang up to one-fourth of the actual joist span,  $L_J$ . See FIGURE 1 through FIGURE 3 for joist span types. Use TABLE 1 to determine your joist size based on span length and joist spacing.



**FIGURE 1: JOIST SPAN - DECK ATTACHED AT HOUSE**



**FIGURE 2: JOIST SPAN - JOISTS ATTACHED TO SIDE OF BEAM**



**FIGURE 3: JOIST SPAN - FREE-STANDING DECK**

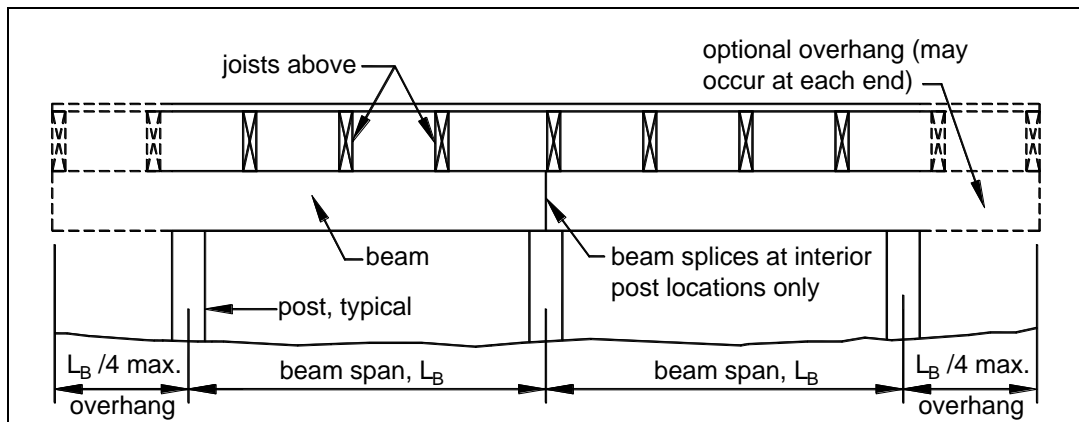
**TABLE 1: MAXIMUM JOIST SPAN LENGTH, J<sup>1</sup>**

Joist Size	Joists without Overhangs			Joists with Overhangs		
	joist spacing, on center			joist spacing, on center		
	12"	16"	24"	12"	16"	24"
2x8	13'-8"	12'-5"	10'-2"	10'-6"	10'-6"	10'-2"
2x10	17'-5"	15'-10"	13'-1"	15'-2"	15'-2"	13'-1"
2x12	18'-0"	18'-0"	15'-5"	18'-0"	18'-0"	15'-5"

<sup>1</sup> Spans are based on 40 PSF live load, 10 PSF dead load, southern pine#2, normal loading duration, wet service conditions and deflection:  $\Delta = \ell/360$  for main span and  $\ell/180$  for overhang.

**BEAM SIZE AND ASSEMBLY REQUIREMENTS**

Beam size is determined using TABLE 2. Beams may overhang up to one-fourth of the actual beam span, B, as shown in FIGURE 4.



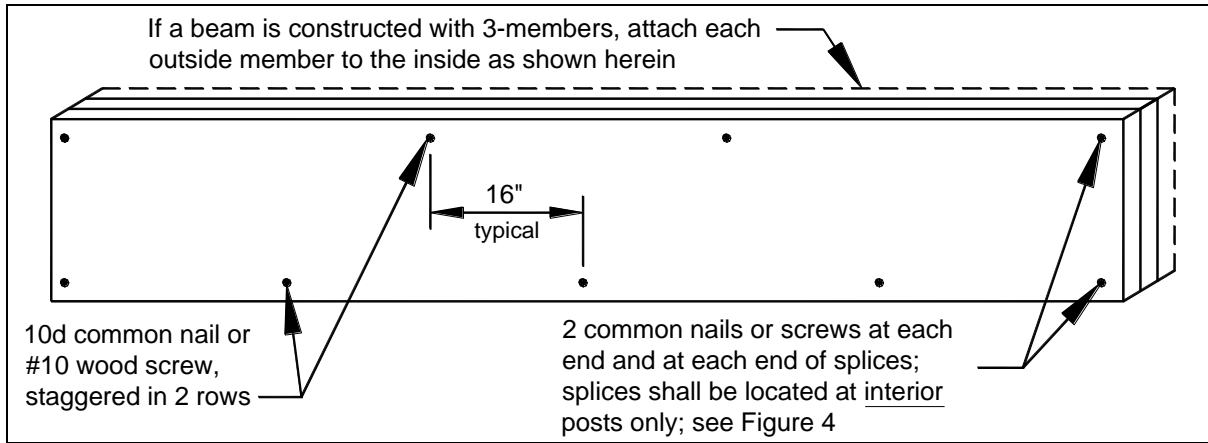
**FIGURE 4: BEAM SPAN TYPES**

**TABLE 2: MAXIMUM BEAM SPAN LENGTH, L<sub>B</sub><sup>1</sup>**

Joist Span	Beam Size							
	(2)2x6	(2)2x8	(2)2x10	(2)2x12	(3)2x6	(3)2x8	(3)2x10	(3)2x12
0 - 6'-0"	7'-1"	9'-2"	11'-10"	13'-11"	8'-7"	11'-4"	14'-5"	17'-5"
6'-1" - 8'-0"	6'-2"	7'-11"	10'-3"	12'-0"	7'-8"	9'-11"	12'-10"	15'-1"
8'-1" - 10'-0"	5'-6"	7'-1"	9'-2"	10'-9"	6'-11"	8'-11"	11'-6"	13'-6"
10'-1" - 12'-0"	5'-0"	6'-6"	8'-5"	9'-10"	6'-3"	8'-1"	10'-6"	12'-4"
12'-1" - 14'-0"	4'-8"	6'-0"	7'-9"	9'-1"	5'-10"	7'-6"	9'-9"	11'-5"
14'-1" - 16'-0"	4'-4"	5'-7"	7'-3"	8'-6"	5'-5"	7'-0"	9'-1"	10'-8"
16'-1" - 18'-0"	4'-1"	5'-3"	6'-10"	8'-0"	5'-2"	6'-7"	8'-7"	10'-1"

<sup>1</sup> Spans are based on 40 PSF live load, 10 PSF dead load, southern pine#2, normal loading duration, wet service conditions and deflection:  $\Delta = \ell/360$  for main span and  $\ell/180$  for overhang with a 230 lb point load.

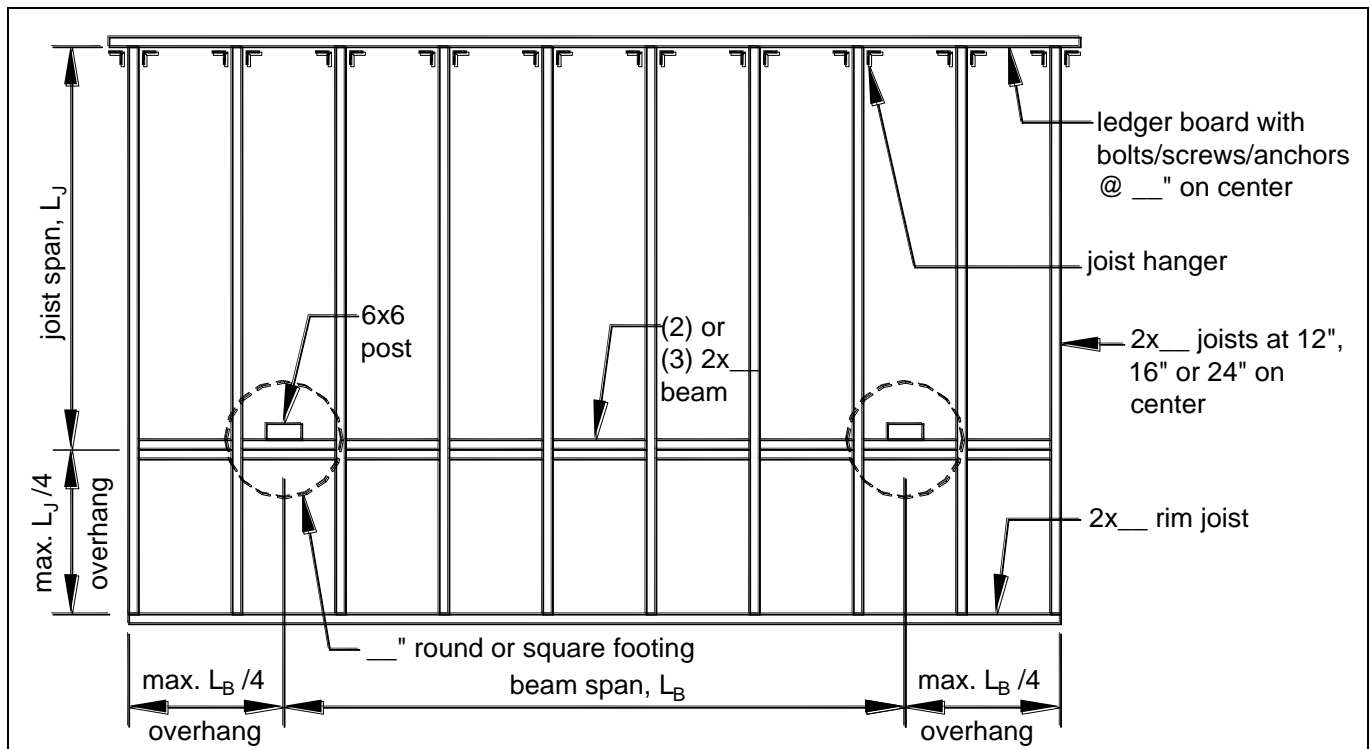
The beam is assembled by attaching the members identified in TABLE 2 in accordance with FIGURE 5.



**FIGURE 5: BEAM ASSEMBLY DETAIL**

**DECK FRAMING PLAN**

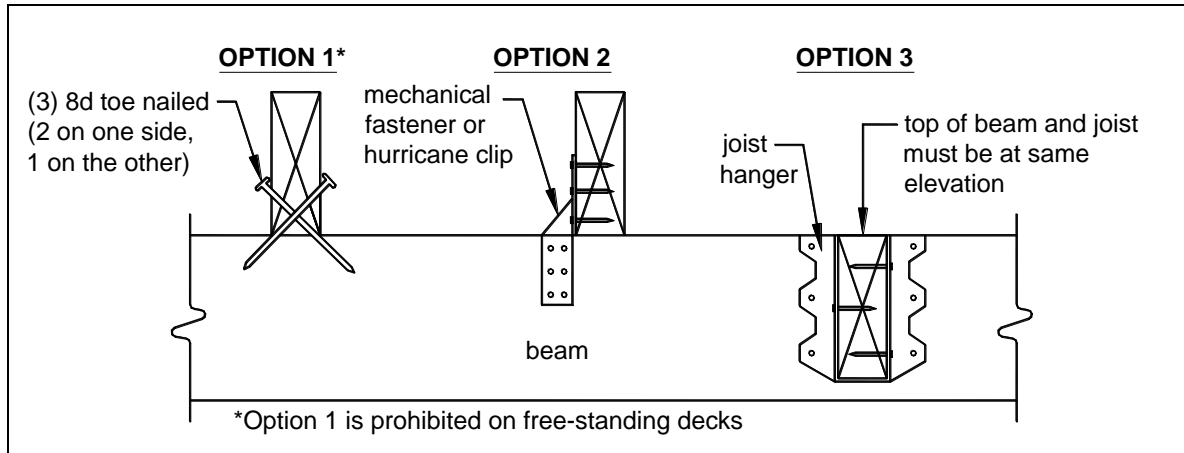
A framing plan shows a bird's-eye view of the joist and beam layout; the location of the ledger board, posts and footings, and the type, size and spacing of the ledger board fasteners. See FIGURE 6 for an example of a typical deck framing plan.



**FIGURE 6: TYPICAL DECK FRAMING PLAN**

## JOIST-TO-BEAM CONNECTION

Each joist shall be attached to the beam as shown in FIGURE 7. Use Option 1 or Option 2 when joists bear on or overhang past the beam; see FIGURE 1 and FIGURE 3. Use Option 3 when joists attach to the side of the beam; see FIGURE 2. Mechanical fasteners or hurricane clips used in Option 2 shall have a minimum capacity of 100 lbs in both uplift and lateral load directions. See manufacturer's recommendations for additional requirements. See JOIST HANGERS on Sheet 10 for more information.



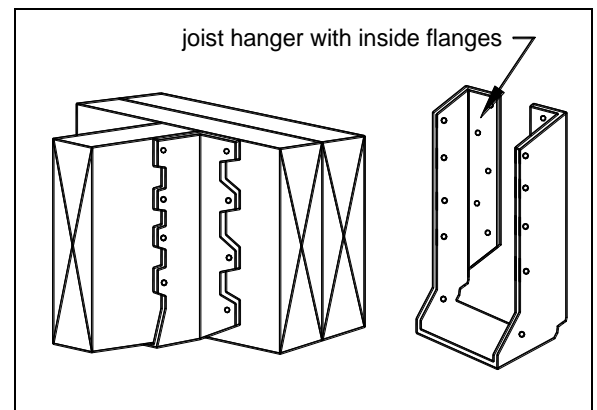
**FIGURE 7: JOIST-TO-BEAM DETAIL**

## JOIST HANGERS

Joist hangers, as shown in FIGURE 8, shall have a minimum capacity of 600 lbs for 2x8s, 700 lbs for 2x10s and 800 lbs for 2x12s. The depth and width of the joist hanger shall equal the dimensions of the member it is carrying. Joist hangers shall be galvanized per the requirements on Sheet 5.

Use joist hangers with inside flanges when clearances to the edge of the beam or ledger board dictate.

**Do not use clip angles or brackets to support framing members. Do not bend hanger flanges to accommodate field conditions.**



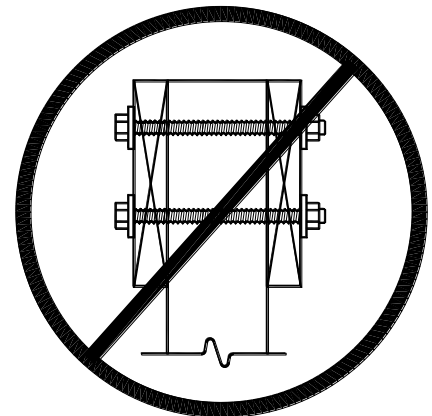
**FIGURE 8: TYPICAL JOIST HANGERS**

## POST REQUIREMENTS

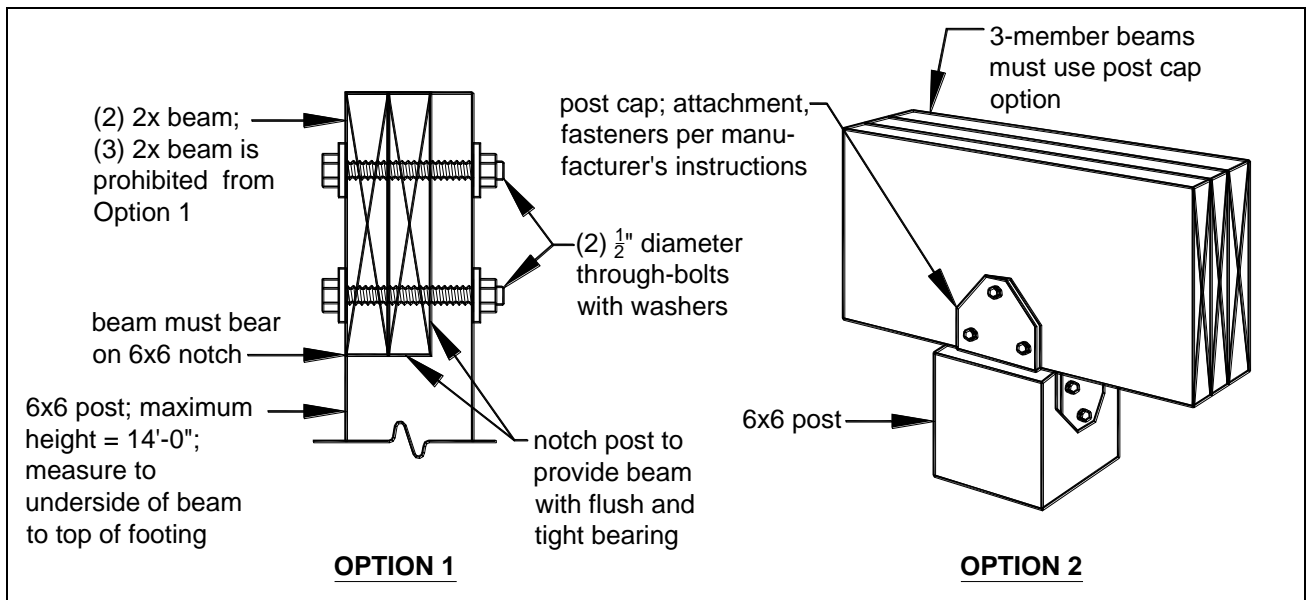
All deck posts shall be 6x6 with a maximum height of 14'-0" measured from the top of the footing to the underside of the beam. The beam shall be attached to the post by one of the two methods shown in FIGURE 10. Attachment of the beam to the side of the post without notching is prohibited; see FIGURE 9

The post cap shown in FIGURE 10, Option 2, shall be specifically designed for (2) 2x or (3) 2x beams and 6x6 posts with a minimum downward allowable load capacity of 5,000 lbs. Attachment shall be per manufacturer's instructions. Post caps shall be galvanized per the requirements on Sheet 5.

Cut ends of posts shall be field treated with a wood preservative containing **copper naphthenate**. Such products can be found in most hardware or home center stores in the paint department.



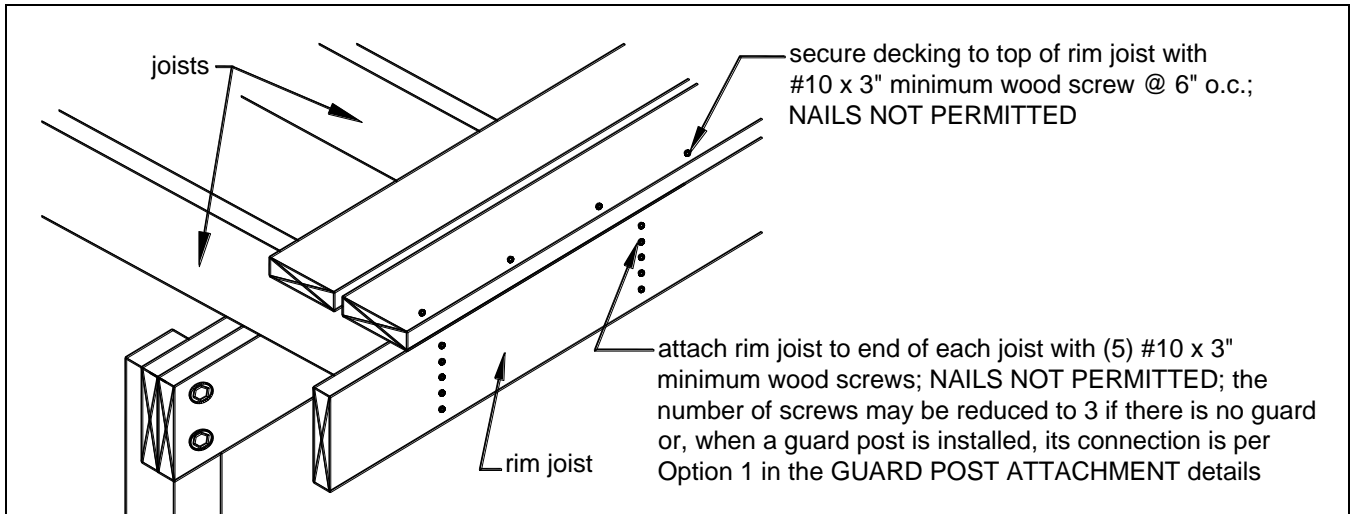
**FIGURE 9: PROHIBITED POST-TO-BEAM ATTACHMENT CONDITION**



**FIGURE 10: POST-TO-BEAM CONNECTION OPTIONS**

**RIM JOIST REQUIREMENTS**

Attach a continuous rim joist to the ends of joists as shown in FIGURE 11. Attach decking to the rim joist as shown in FIGURE 11. For more decking attachment requirements, see **DECKING REQUIREMENTS** on Sheet 5.



**FIGURE 11: RIM JOIST CONNECTION DETAILS**

**FOOTINGS**

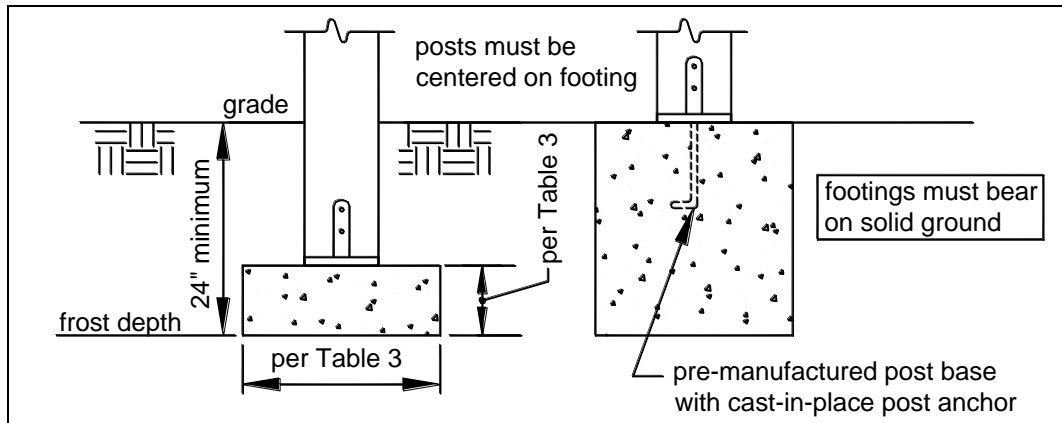
The concrete for all footings shall have a minimum compressive strength of 2,500 PSI concrete. See TABLE 3 for footing size and footing thickness; see FIGURE 12 for post attachment options and requirements. Post anchors shall be galvanized per the requirements on Sheet 5. All footings shall bear on solid ground; bearing conditions shall be verified in the field by county inspectors prior to placement of concrete. **DECK FOOTINGS CLOSER THAN 5'-0" TO AN EXISTING EXTERIOR HOUSE WALL MUST BEAR AT THE SAME ELEVATION AS THE EXISTING HOUSE FOOTINGS.**

**Do not construct footings over utility lines or enclosed meters. Call Miss Utility at 811 before you dig.**

**TABLE 3: FOOTING SIZE**

Beam Span, $L_B$	Joist Span, $L_J$	Footing Size		Minimum Thickness*
		Square	Round	
0 - 8'-0"	0 - 10'-0"	16"	18"	8"
	10'-1" - 14'-0"	16"	18"	8"
	14'-1" - 18'-0"	18"	20"	10"
8'-1" - 12'-0"	0 - 10'-0"	16"	18"	8"
	10'-1" - 14'-0"	22"	24"	10"
	14'-1" - 18'-0"	22"	24"	10"
12'-1" - 17'-5"	0 - 10'-0"	22"	24"	10"
	10'-1" - 14'-0"	24"	26"	12"

\* The pre-manufactured post base may have a footing thickness requirement greater than the value in the table above due to the dimension of the cast-in-place anchor. In such cases, the manufacturer's specified minimum footing thickness shall govern.



**FIGURE 12: TYPICAL FOOTING OPTIONS**

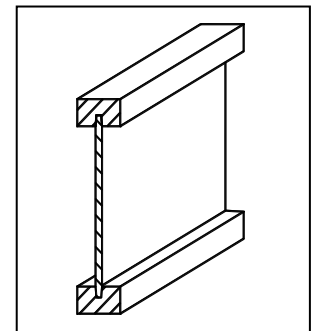
**LEDGER ATTACHMENT REQUIREMENTS**

**GENERAL:** Attach the ledger board, which shall be greater than or equal to the joist depth, to the existing exterior wall in accordance with FIGURE 14 through FIGURE 16. When attachments are made to the existing house band board, the band board shall be capable of supporting the new deck. If this cannot be verified or conditions at the existing house differ from the details herein, then a free-standing deck is required. See **FREE-STANDING DECKS** on Sheet 16.

**YOU MUST VERIFY THE EXISTING CONDITIONS IN THE FIELD PRIOR TO APPLYING FOR A BUILDING PERMIT. COMPLIANCE WITH ALL THE REQUIREMENTS HEREIN IS CRITICAL TO ENSURE THE STRUCTURAL STABILITY OF YOUR DECK AND THE SAFETY OF YOU AND YOUR FAMILY.**

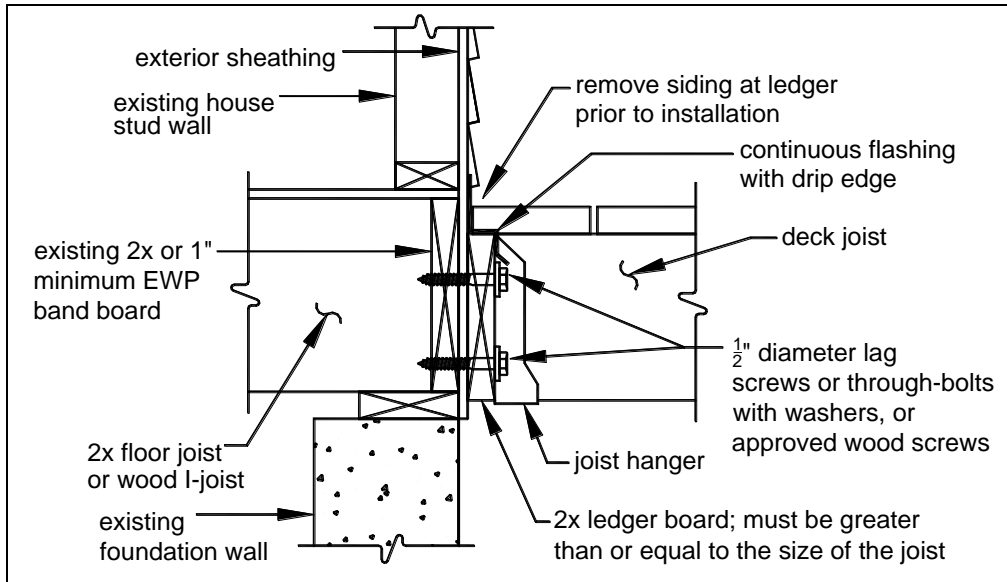
**SIDING AND FLASHING:** House siding, or the exterior finish system, must be removed prior to the installation of the ledger board. Flashing is required at any ledger board connection to a wall of wood framed construction and shall be composed of copper (attached using copper nails), stainless steel, UV resistant plastic or galvanized steel coated with 1.85 oz/sf of zinc (G-185 coating). See FIGURE 14 for continuous flashing with drip edge. The threshold shall be carefully flashed and caulked to prevent water intrusion due to splashing from the deck or melting snow and ice.

**WOOD I-JOISTS:** Many new homes constructed with wood I-joists, see FIGURE 13, have a 1" or thicker manufactured engineered wood product (EWP) as the band board that can support the attachment of a deck; see FIGURE 14. However, older homes constructed with wood I-joists may not have a band board capable of supporting a deck. Some may have plywood band boards with a thickness of less

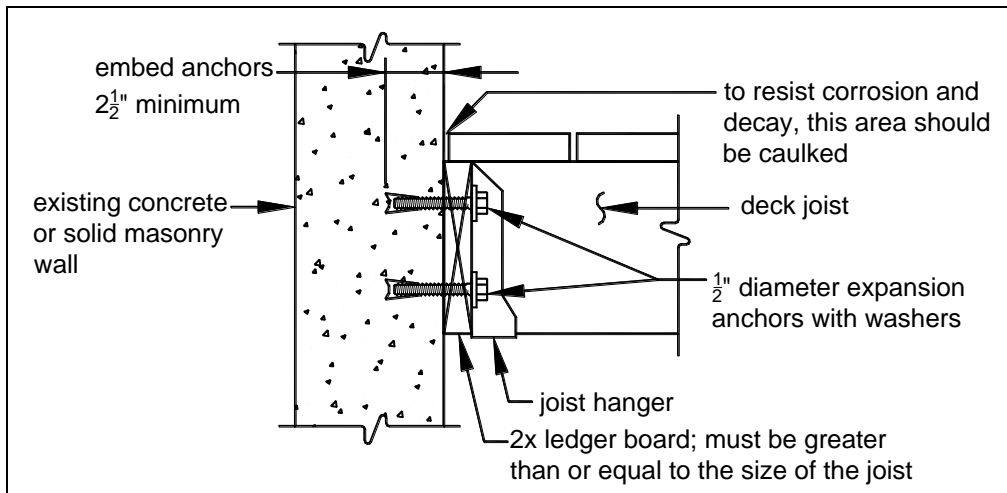


**FIGURE 13: WOOD I-JOIST PROFILE**

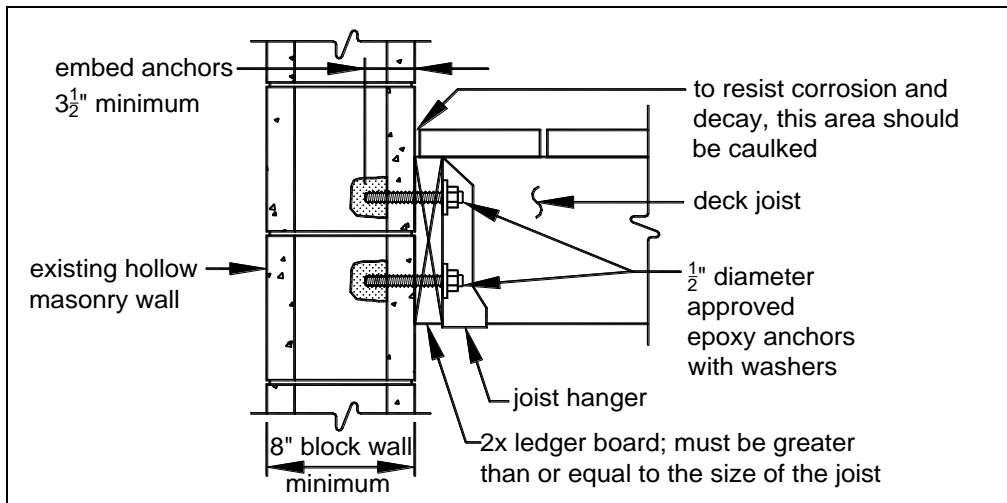
than 1". Others may have an I-joist as the band board. In these cases a free-standing deck is required. See FREE-STANDING DECKS on Sheet 16.



**FIGURE 14: ATTACHMENT OF LEDGER BOARD-TO-BAND BOARD**



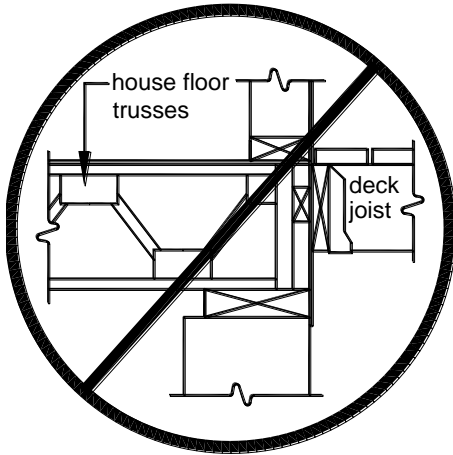
**FIGURE 15: ATTACHMENT OF LEDGER BOARD-TO-FOUNDATION WALL (CONCRETE OR SOLID MASONRY)**



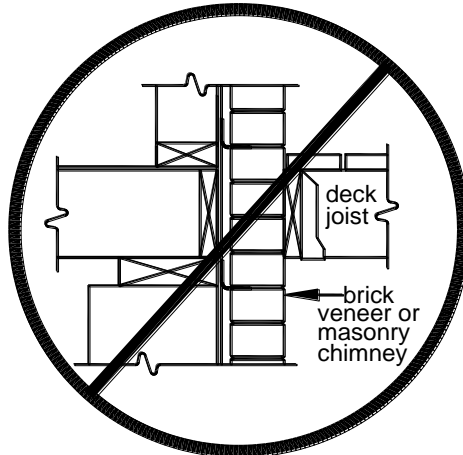
**FIGURE 16: ATTACHMENT OF LEDGER BOARD-TO-FOUNDATION WALL (HOLLOW MASONRY)**

## PROHIBITED LEDGER ATTACHMENTS

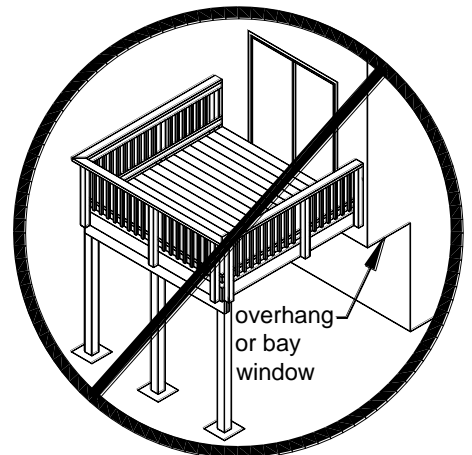
Attachments to the ends of pre-manufactured open web joists, to brick veneers or chimneys, and to house overhangs or bay windows are strictly prohibited; see FIGURE 17 through FIGURE 19. In such cases the deck shall be free-standing. See FREE-STANDING DECKS on Sheet 16.



**FIGURE 17: NO ATTACHMENT TO OPEN WEB TRUSSES**



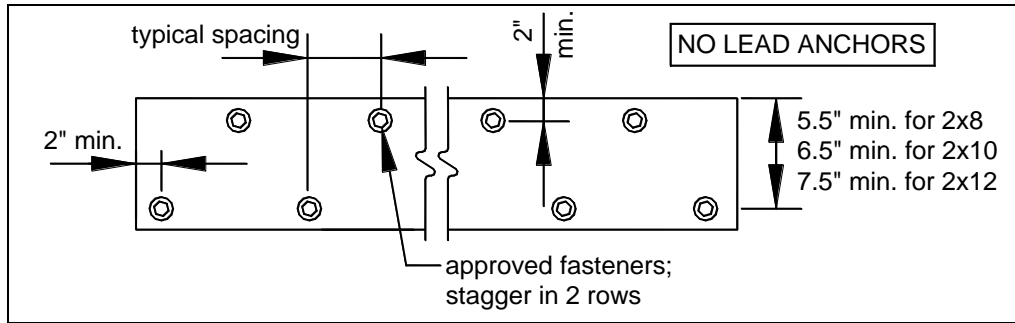
**FIGURE 18: NO ATTACHMENT TO OR THROUGH BRICK VENEER**



**FIGURE 19: NO ATTACHMENT TO HOUSE OVERHANG**

## LEDGER BOARD FASTENERS

Ledger board fasteners shall be installed in accordance with FIGURE 20 and the spacing in TABLE 4. Only those fastener types noted herein are approved for use; LEAD ANCHORS ARE STRICTLY PROHIBITED. Adequacy of connections will be verified by county inspectors.



**FIGURE 20: LEDGER BOARD FASTENER SPACING AND CLEARANCES**

**TABLE 4: LEDGER BOARD FASTENER SPACING<sup>1</sup>**

Fastener	Band Board Material <sup>2</sup>	Joist Span						
		0 to 6'-0"	6'-1" to 8'-0"	8'-1" to 10'-0"	10'-1" to 12'-0"	12'-1" to 14'-0"	14'-1" to 16'-0"	16'-1" to 18'-0"
		Spacing of Fasteners, on center						
Lag Screws	1" EWP	24"	18"	14"	12"	10"	9"	8"
	1-1/8" EWP	28"	21"	16"	14"	12"	10"	9"
	2x lumber	30"	23"	18"	15"	13"	11"	10"
Through Bolts	1" EWP	24"	18"	14"	12"	10"	9"	8"
	1-1/8" EWP	28"	21"	16"	14"	12"	10"	9"
	2x lumber	36"	36"	34"	29"	24"	21"	19"
Approved Wood Screws	1" EWP	18"	13"	11"	9"	8"	7"	6"
	1-1/8" EWP	21"	15"	12"	10"	9"	7"	7"
	2x lumber	19"	14"	11"	9"	8"	7"	6"
Expansion Anchors		36"	36"	34"	29"	24"	21"	19"
Approved Epoxy Anchors		32"	32"	32"	24"	24"	16"	16"

<sup>1</sup>See Sheet 15 for fastener specifications.

<sup>2</sup>EWP = manufactured engineered wood product; see Sheet 12 for more information.

### Through-Bolts

Through-bolts shall have a minimum diameter of 1/2". Pilot holes for through-bolts shall be 17/32" to 9/16" in diameter. Through-bolts must be equipped with washers at the bolt head and nut.

### Expansion Anchors

Use expansion anchors when attaching a ledger board to a concrete or solid masonry wall as shown in FIGURE 15. Bolt diameters of the anchors shall be a minimum of 1/2"; in some cases, this may require an anchor size of 5/8". Minimum embedment length shall be 2-1/2". Expansion anchors must have washers. Approved epoxy anchors may be substituted for expansion anchors; see below for minimum requirements.

### Epoxy Anchors

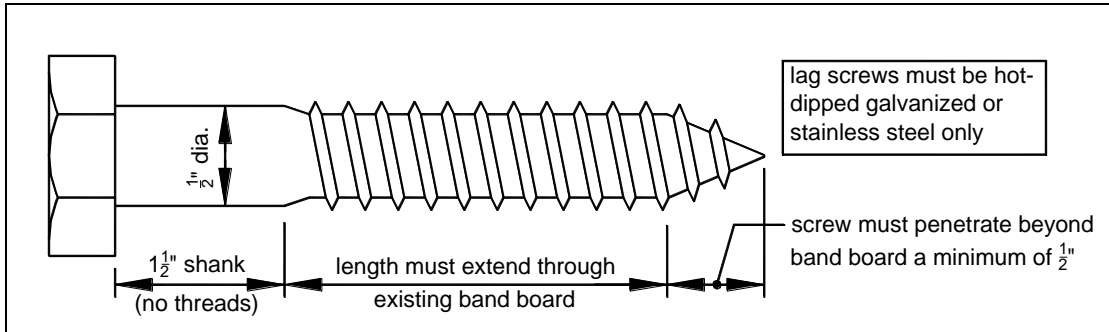
When attaching to hollow masonry, use one of the approved epoxy anchors listed in TABLE 5 and install as shown in FIGURE 16. Epoxy anchors shall have a minimum diameter of 1/2" and minimum embedment length of 3-1/2". Installation shall be in strict conformance to the manufacturer's instructions. Epoxy anchors must have washers.

**TABLE 5: APPROVED EPOXY ANCHORS**

Manufacturer	Product
ITW Ramset/Red Head	Epcon Acrylic 7
Hilti	HY-20

Lag Screws

Lag screws shall have a minimum diameter of 1/2" and shall be hot-dipped galvanized or stainless steel. Lag screws may be used only when the field conditions match those shown in FIGURE 14. See FIGURE 21 for lag screw length and shank requirements. All lag screws shall be installed with washers.



**FIGURE 21: LAG SCREW REQUIREMENTS**

**LAG SCREW INSTALLATION REQUIREMENTS:** Each lag screw shall have pilot holes drilled as follows: 1) Drill a 1/2" diameter hole in the ledger board, 2) Drill a 5/16" diameter hole into the solid connection material of the existing house. **DO NOT DRILL A 1/2" DIAMETER HOLE INTO THE SOLID CONNECTION MATERIAL.**

The threaded portion of the lag screw shall be inserted into the pilot hole by turning. **DO NOT DRIVE WITH A HAMMER.** Use soap or a wood-compatible lubricant as required to facilitate tightening. Each lag screw shall be thoroughly tightened snug, but shall not be overly tightened so as to cause wood damage.

Wood Screws

The approved wood screws listed in

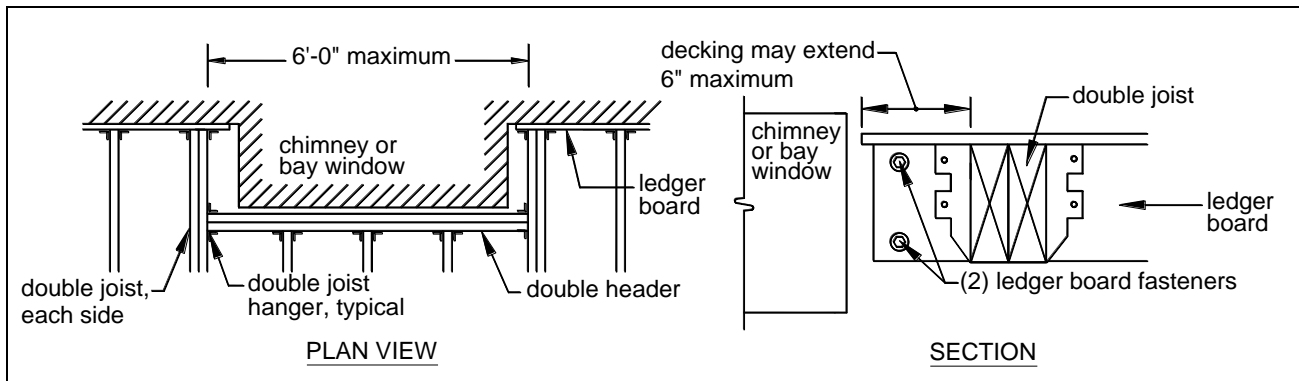
TABLE 6 are similar to lag screws and have an integrated washer. However, no pilot holes are required for installation. The screws shall have a minimum diameter not less than 1/4" and shall be of sufficient length to fully penetrate the existing house band board. Installation shall be in strict conformance with the manufacturer's instructions.

**TABLE 6: APPROVED WOOD SCREWS**

Manufacturer	Product
FastenMaster	LedgerLok
Simpson Strong-Tie	Strong-Drive Screw (SDS)

**FRAMING AT CHIMNEY OR BAY WINDOW**

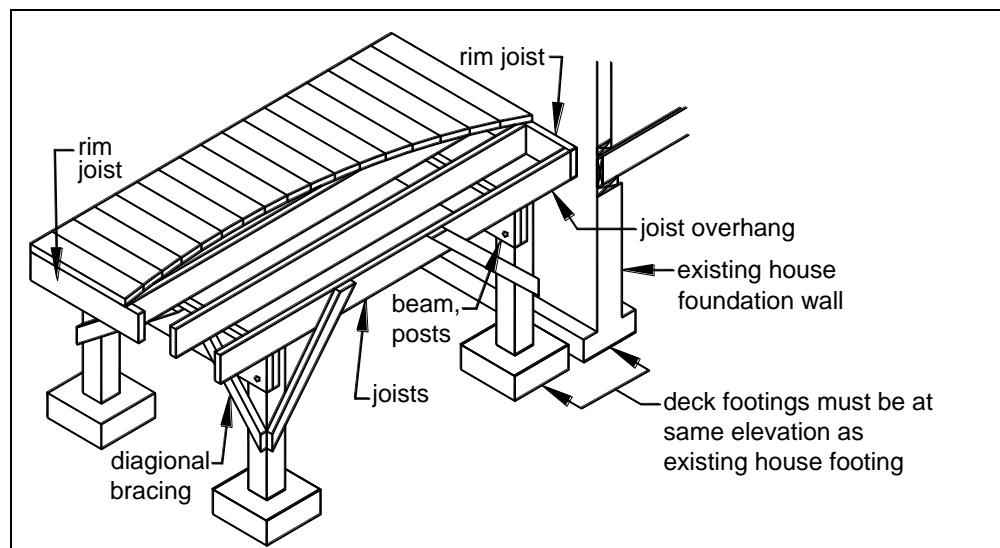
All members at a chimney or bay window shall be framed in accordance with FIGURE 22. Headers may span a maximum of 6'-0". When a chimney or bay window is wider than 6'-0", one or more 6x6 posts may be added to reduce header spans to less than 6'-0". In such cases, the post footing must meet the requirements on Sheet 11. Headers with a span length greater than 6'-0" require a plan submission.



**FIGURE 22: REQUIREMENTS FOR FRAMING AT CHIMNEY OR BAY WINDOW**

### **FREE-STANDING DECKS**

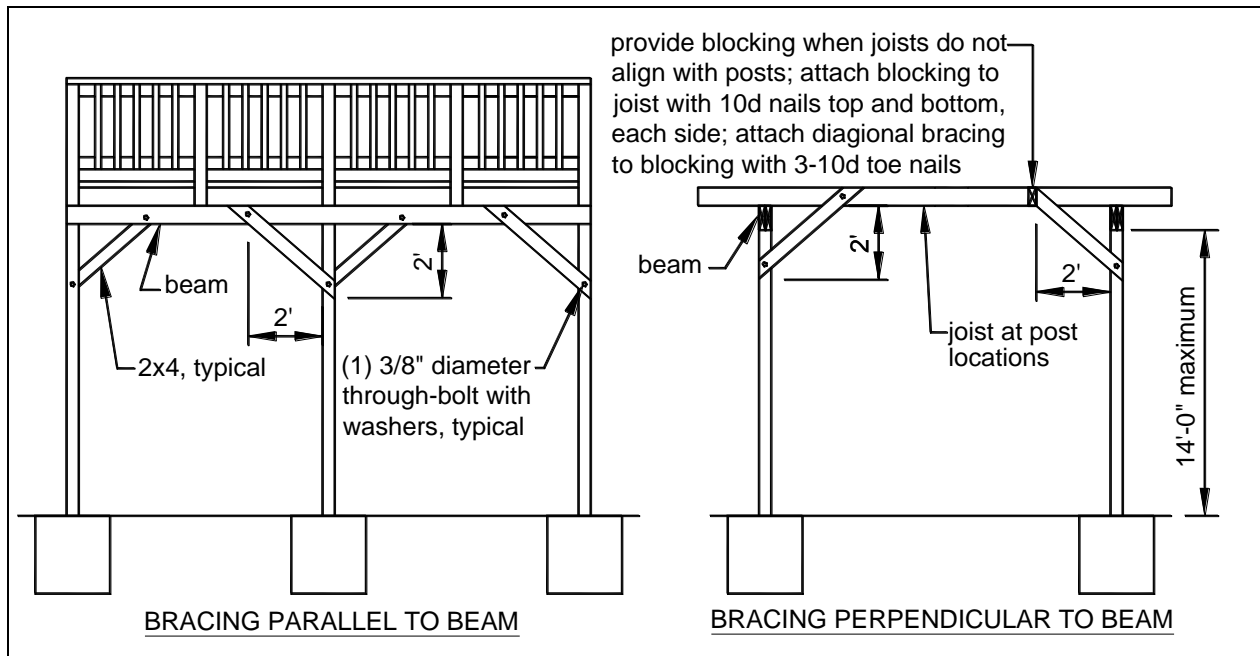
Decks which are free-standing do not utilize the exterior wall of the existing house to support vertical loads; instead, an additional beam with posts is provided at or offset from the existing house. **THE ASSOCIATED DECK POST FOOTINGS SHALL BE PLACED AT THE SAME ELEVATION AS THE EXISTING HOUSE FOOTING.** See FIGURE 3 and FIGURE 23. Beam size is determined by TABLE 2.



**FIGURE 23: FREE-STANDING DECK**

### **LATERAL SUPPORT OF FREE-STANDING DECKS**

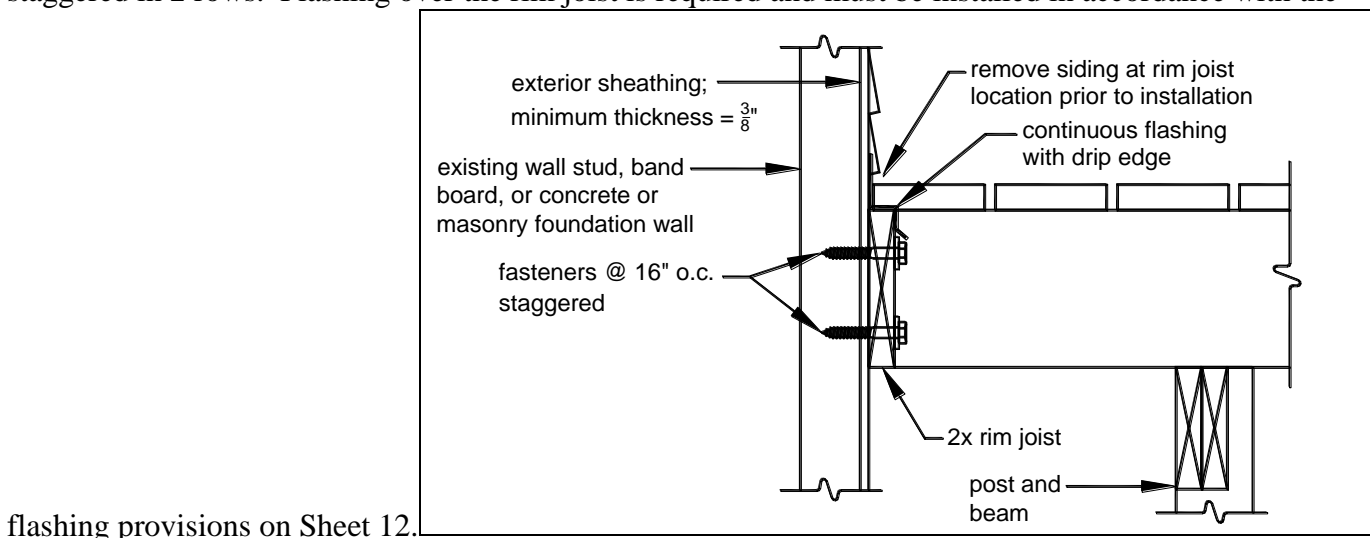
Free standing decks greater than 2 feet above grade shall resist lateral loading and horizontal movement by providing diagonal bracing or by attaching the deck to the exterior wall of the house.



**FIGURE 24: DIAGONAL BRACING REQUIREMENTS**

**DIAGONAL BRACING:** Provide diagonal bracing both parallel and perpendicular to the beam at each post as shown in FIGURE 24. When parallel to the beam, the bracing shall be bolted to the post at one end and beam at the other. When perpendicular to the beam, the bracing shall be bolted to the post at one end and a joist at the other. When a joist does not align with the bracing location, provide blocking between the next adjacent joists; attach as noted in the figure.

**ATTACHMENT TO HOUSE:** Attach the deck rim joist to the existing house exterior wall as shown in FIGURE 25. The wall must be sheathed with a minimum  $\frac{3}{8}$ " structural panel sheathing. Use lag screws or through-bolts when fastening to an existing band board or wall stud; use expansion anchors or epoxy anchors when fastening to concrete or masonry. **LEAD ANCHORS ARE STRICTLY PROHIBITED. DO NOT USE THIS ATTACHMENT METHOD IF A BRICK VENEER IS PRESENT. YOU MUST VERIFY THIS CONDITION IN THE FIELD PRIOR TO UTILIZING THIS METHOD.** Fasteners shall be 16" on center and staggered in 2 rows. Flashing over the rim joist is required and must be installed in accordance with the

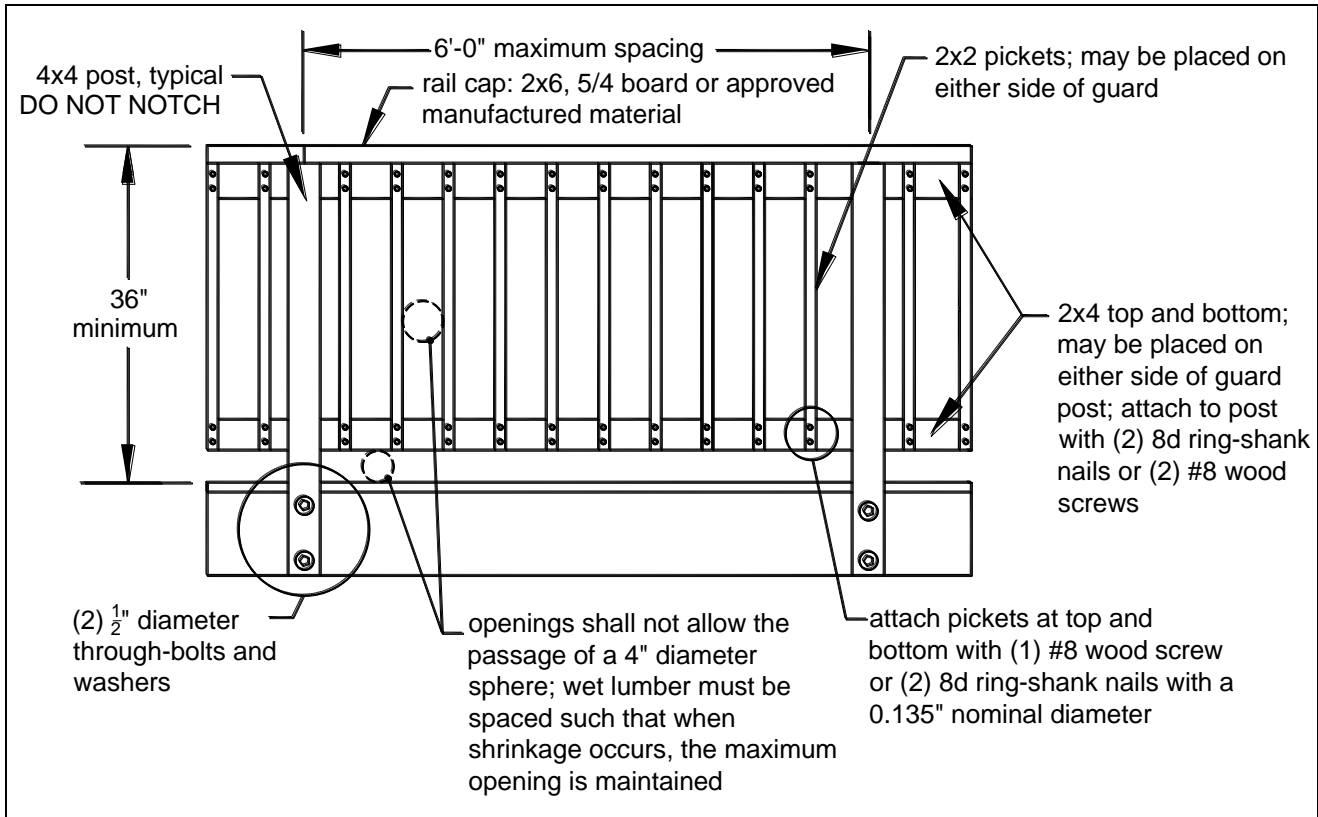


flashing provisions on Sheet 12.

**FIGURE 25: ATTACHMENT TO HOUSE LATERAL SUPPORT**

## GUARD REQUIREMENTS

All decks greater than 30" above grade are required to have a guard. If you are providing a guard when one is not required, it must meet these requirements. All guards shall be constructed in strict conformance with the details herein; any deviations require a plan submission.



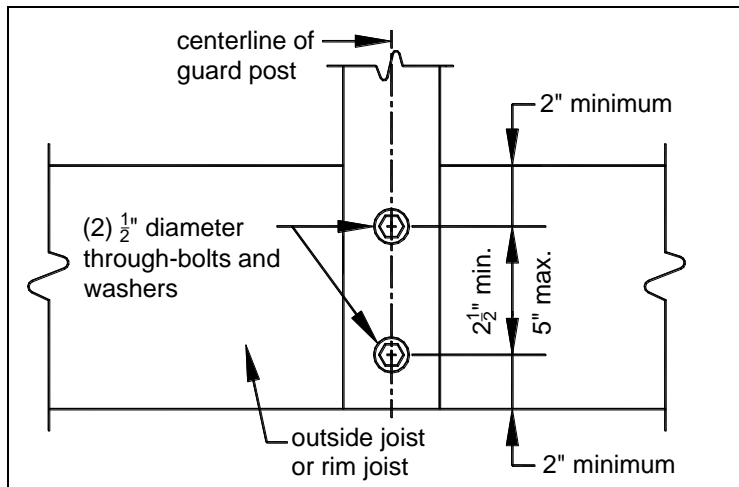
**FIGURE 26: TYPICAL GUARD DETAIL**

The guard cap may be composed of an approved foreign lumber, plastic or composite material provided the product has an approved evaluation report from an accredited testing laboratory which has listed the product. For a list of approved materials, go to the website below. The evaluation report must be on the jobsite and available to the inspector during the inspection process.

Any guard wholly comprised of a pre-fabricated wood, plastic, composite or manufactured guard system purchased from a home center store, lumber company or similar will require a plan submission. **ONLY THOSE SYSTEMS LISTED BY AN ACCREDITED TESTING AGENCY ARE APPROVED FOR USE IN ARLINGTON COUNTY.**



**FIGURE 27: PROHIBITED NOTCHING AT GUARD POSTS**



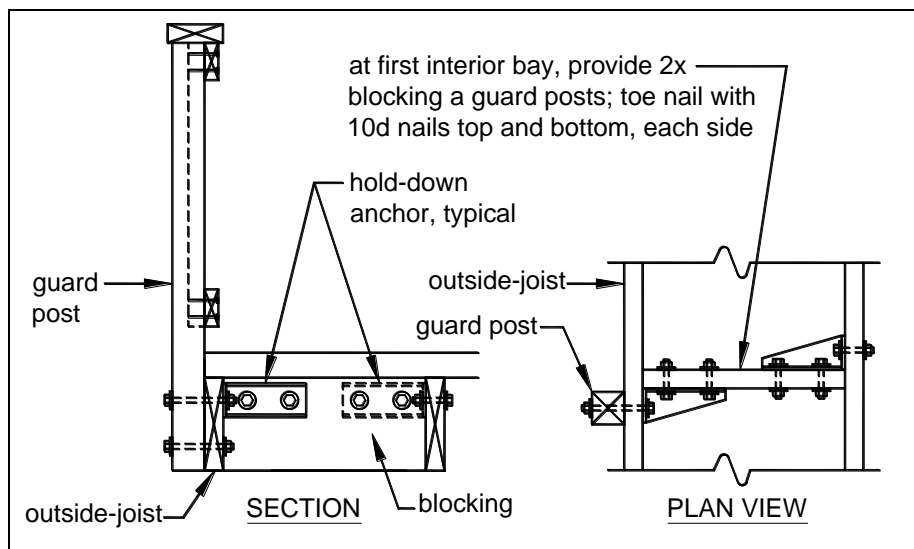
**FIGURE 28: GUARD POST ATTACHMENT DETAIL**

### GUARD POST ATTACHMENTS

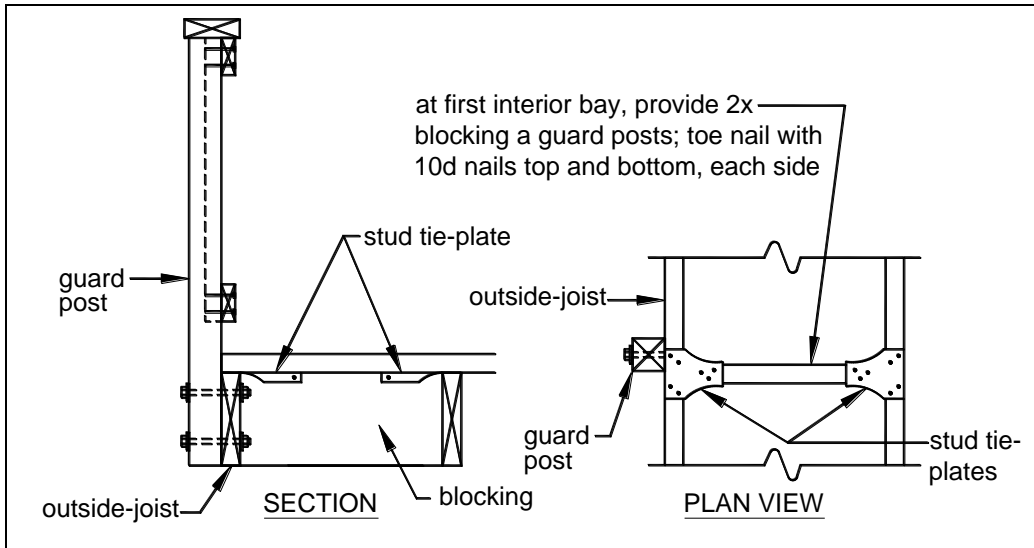
Guard posts must be securely fastened to the deck framing to ensure the entire guard can resist imposed loads. Whether a guard post is attached to the outside joist or the band joist, the adjacent framing must be strengthened with either *hold-down anchors* or *stud tie-plates* as shown in the attachment figures.

When a *hold-down anchor* is specified, look for the HD2A from Simpson Strong-Tie, HD2A from USP or DeckLok from Morse Technologies. Other hold-down anchor models meeting the minimum requirements may also be used. When a *stud tie-plate* is specified, look for model number SP1 from Simpson Strong-Tie or model number SPT22 from USP. Other stud tie plate models meeting the minimum requirements may also be used. All *hold-down anchors* and *stud tie-plates* shall be galvanized per the requirements on Sheet 5.

**GUARD POST TO OUTSIDE-JOIST:** Guard posts for guards which run parallel to the deck joists (side of deck) shall be attached to the outside-joist using one of the options shown in FIGURE 29 or FIGURE 30.

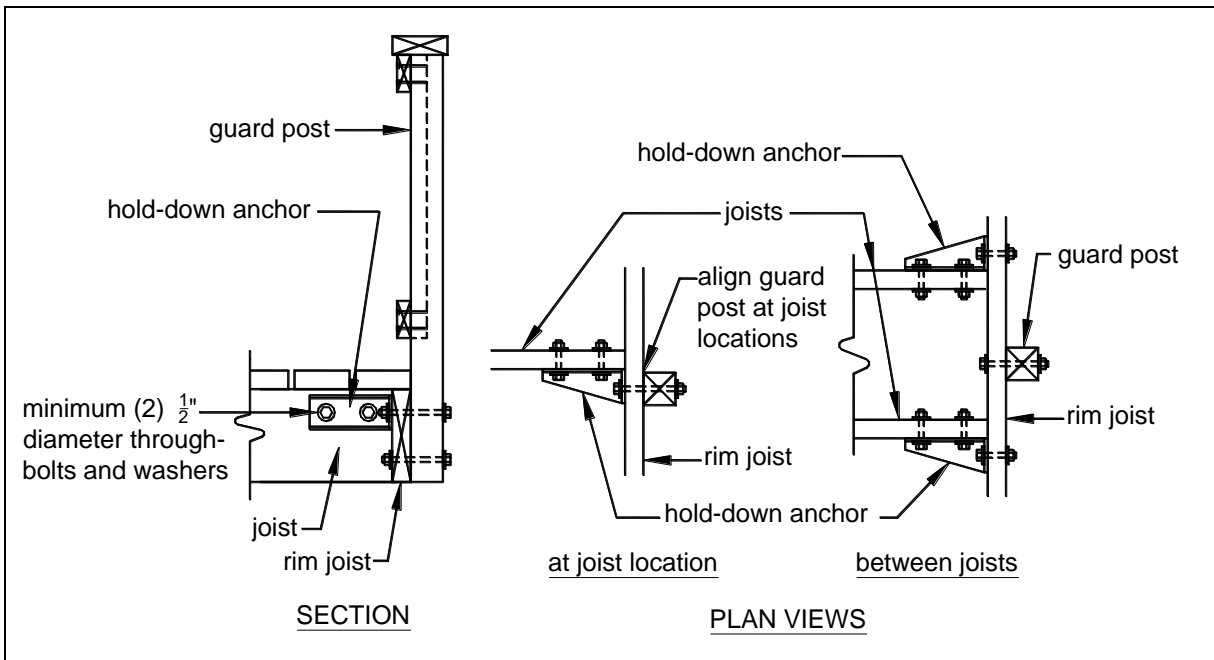


**FIGURE 29: GUARD POST TO OUTSIDE JOIST DETAIL, OPTION 1**

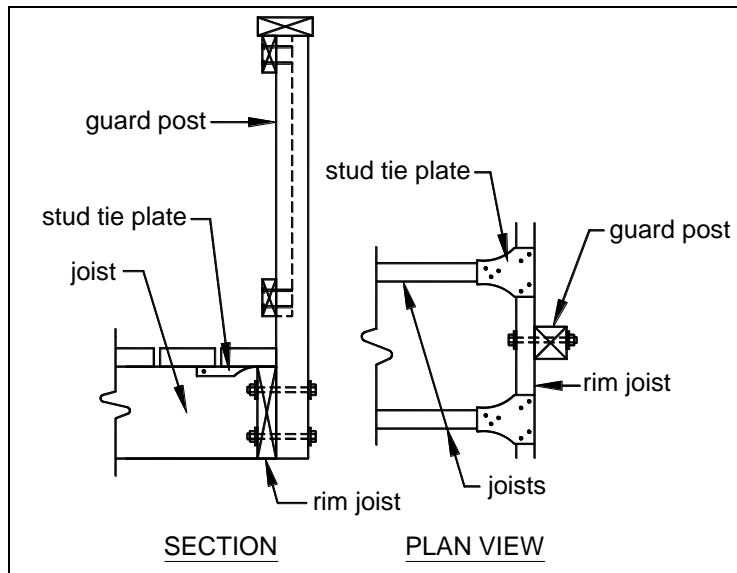


**FIGURE 30: GUARD POST TO OUTSIDE JOIST DETAIL, OPTION 2**

**GUARD POST TO RIM JOIST:** Use one of the options shown in FIGURE 31 and FIGURE 32 to attach a guard post to a rim joist. See FIGURE 11 for rim joist-to-deck joist and decking-to-rim joist attachment requirements.



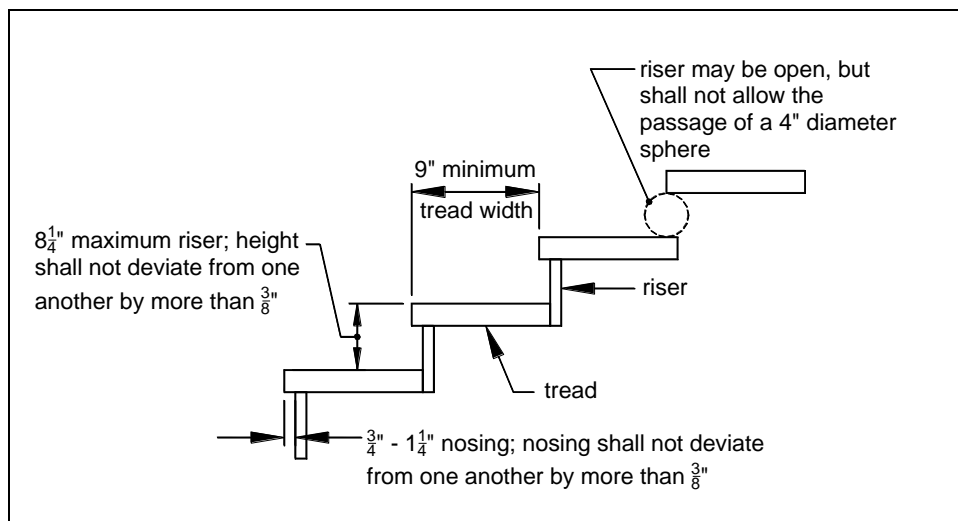
**FIGURE 31: GUARD POST TO RIM JOIST DETAIL, OPTION 1**



**FIGURE 32: GUARD POST TO RIM JOIST DETAIL, OPTION 2**

### STAIR REQUIREMENTS

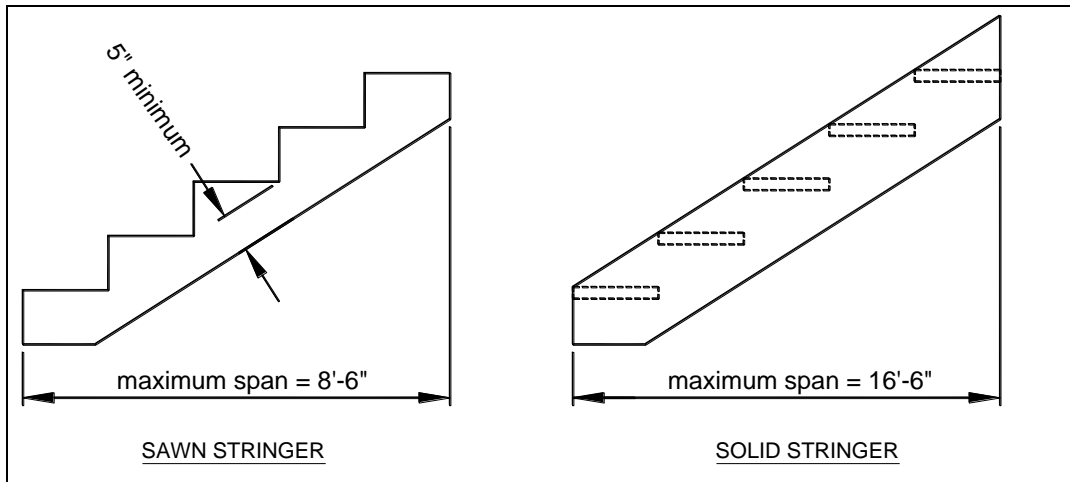
**STAIR GEOMETRY:** Stairs shall be a minimum of 36" in width as shown in FIGURE 41. Tread, riser and nosing dimensions, opening limitations and tolerance minimums shall meet the requirements shown in FIGURE 33. Treads may be framed with 2x lumber or  $\frac{5}{4}$  board. An approved manufactured material may be substituted provided the construction is within the product limitations listed in its evaluation report. See Decking Requirements on Sheet 5 for more information. Risers may be framed with 1x lumber minimum.



**FIGURE 33: TREAD AND RISER DETAIL**

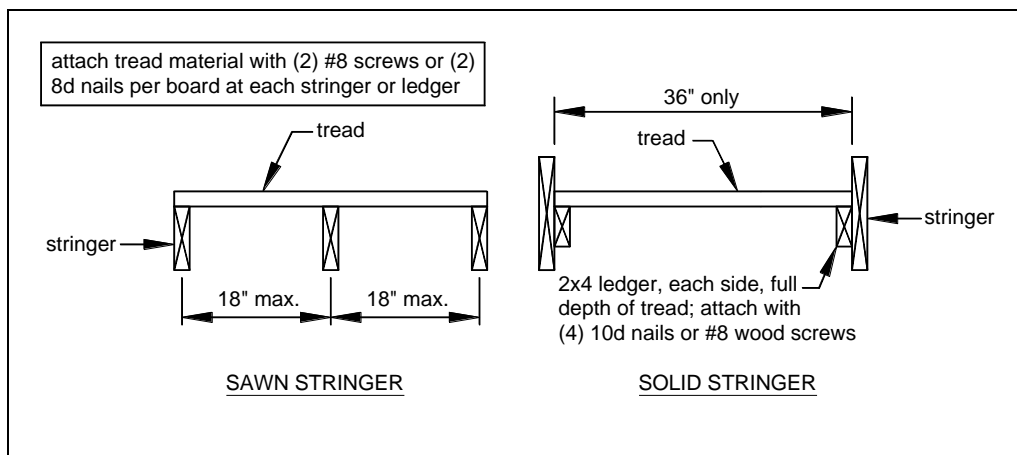
**STAIR STRINGERS:** Stringers shall be 2x12s cut to meet the stair geometry requirements shown in FIGURE 33. Solid 2x12s stringers may be substituted, but for 36" wide stairs only. All stair stringers shall be spaced a maximum of 18" on center, as shown in FIGURE 35. Stairs that are equal to 36" in width and have 2x tread material may be framed with two stringers, either sawn or solid.

All stringers shall not exceed the horizontal span length shown in FIGURE 34. If the stringer span exceeds the maximum limit, a 4x4 post may be provided to support the stringer and shorten its span length. The 4x4 post shall be notched and bolted to the stringer with (2)  $\frac{1}{2}$ " diameter through-bolts with washers per FIGURE 10, Option 1. The post shall be centered on a 12" diameter or 10" square, 4" thick footing. The footing shall bear 24" below grade, and the post shall be attached to the footing per FIGURE 12. An intermediate landing may also be provided to shorten the stringer span; see STAIR LANDINGS.

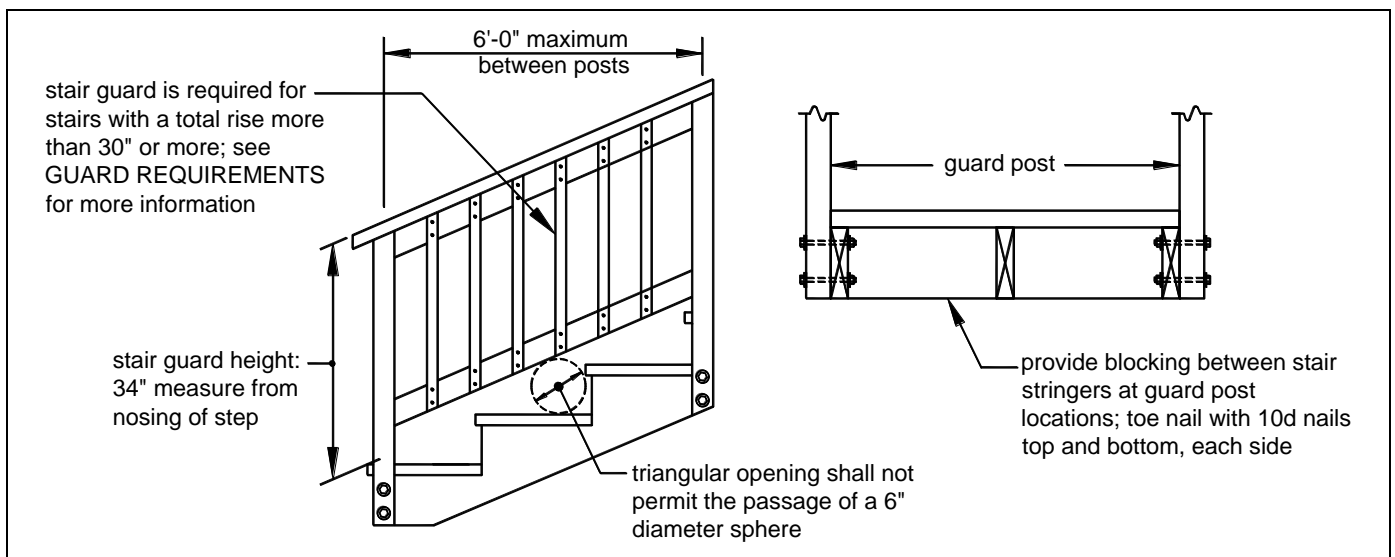


**FIGURE 34: STAIR STRINGER REQUIREMENTS**

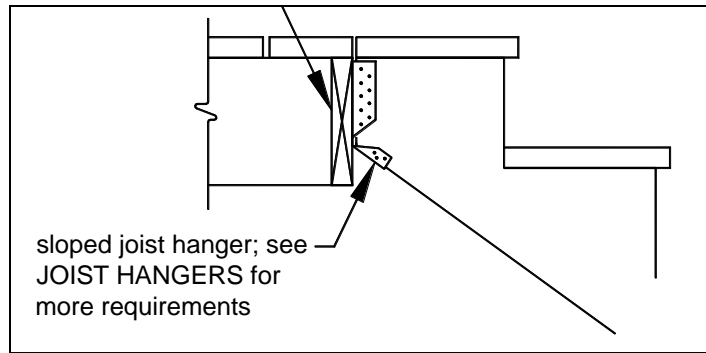
**STAIR LANDINGS:** If the total vertical height of a stairway exceeds 12'-0", then an intermediate landing will be required. All intermediate stair landings shall be designed and constructed as a free-standing deck using the details herein. The width of each landing shall not be less than the width of the stairway served. Every landing shall have a minimum dimension of 36" measured in the direction of travel and not less than the width of the stairway served.



**FIGURE 35: TREAD CONNECTION REQUIREMENTS**

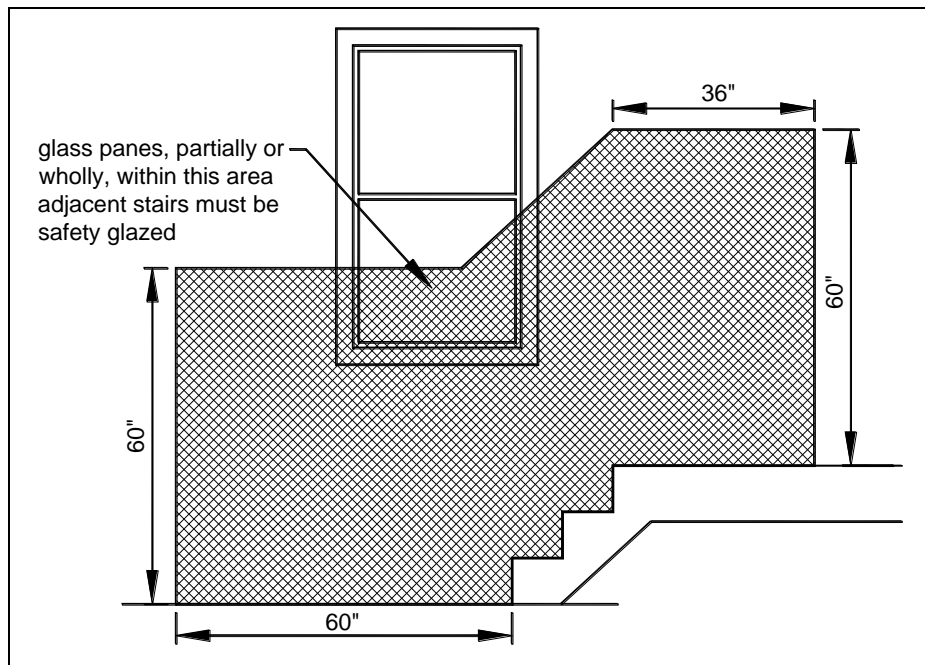


**FIGURE 36: STAIR GUARD REQUIREMENTS**



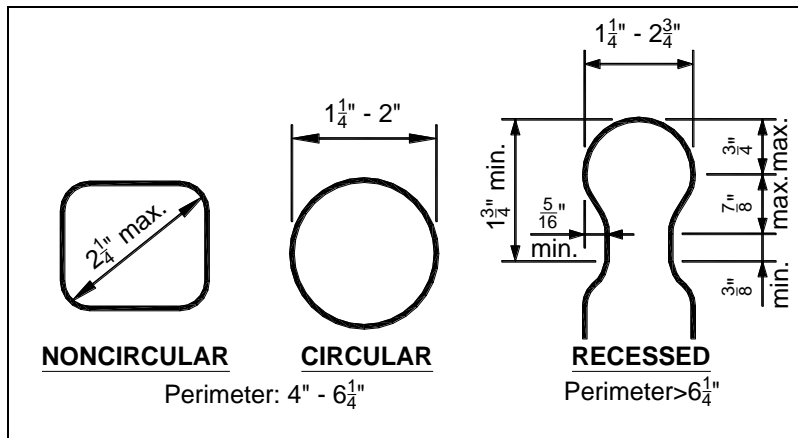
**FIGURE 37: STAIR STRINGER ATTACHMENT DETAIL**

**SAFETY GLAZING REQUIREMENTS:** Safety glazing in window glass is required when the existing house wall acts as a barrier to adjacent stairs, landings and the areas at the top and bottom of the stairs. If a window or portion thereof falls within the area shown in FIGURE 38, the glass panes within that area shall be safety glazed. Safety glazing is required to reduce injury due to an accidental impact when ascending or descending the stairs. For additional safety glazing requirements see the General Notes on Sheet 5.



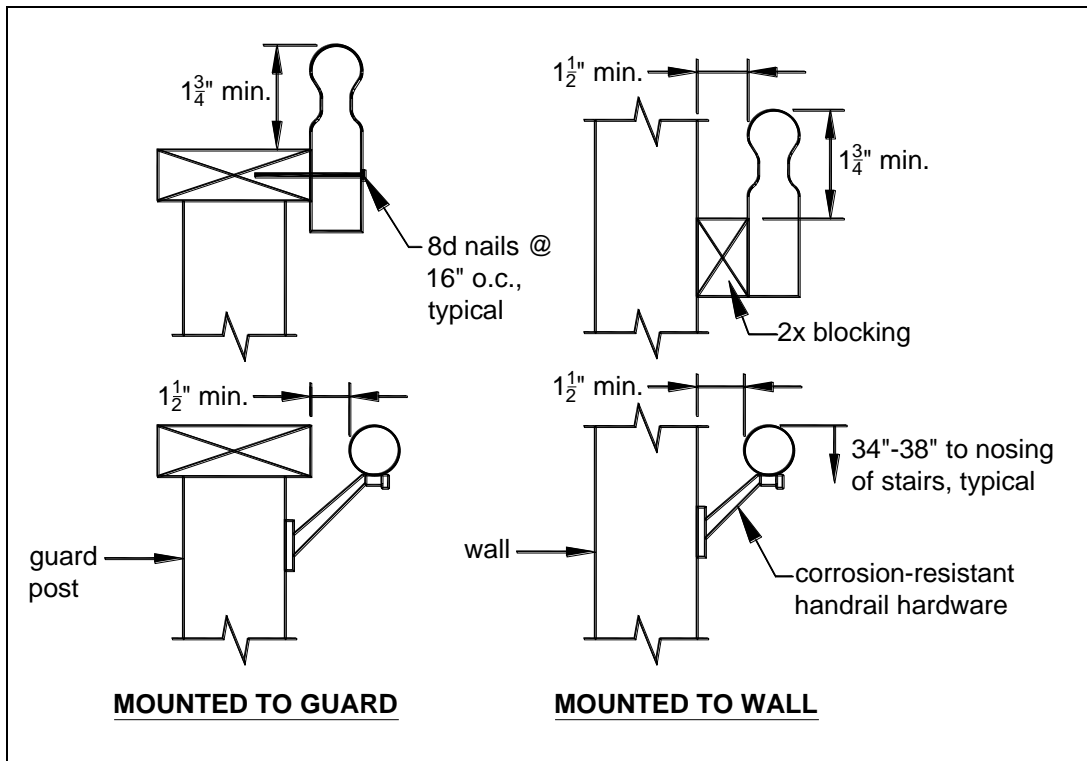
**FIGURE 38: SAFETY GLAZING AREA**

**STAIR HANDRAIL REQUIREMENTS:** All stairs with 4 or more risers shall have a handrail on one side. Handrails shall be graspable per FIGURE 39 and shall be composed of decay-resistant and/or corrosion resistant material. Handrail shall be attached to the stair guard or an existing exterior wall which acts as a barrier to the stairs. See FIGURE 40. All shapes shall have a smooth surface with no sharp corners. Recessed sections may be shaped from 2x6s or  $\frac{5}{4}$  board.

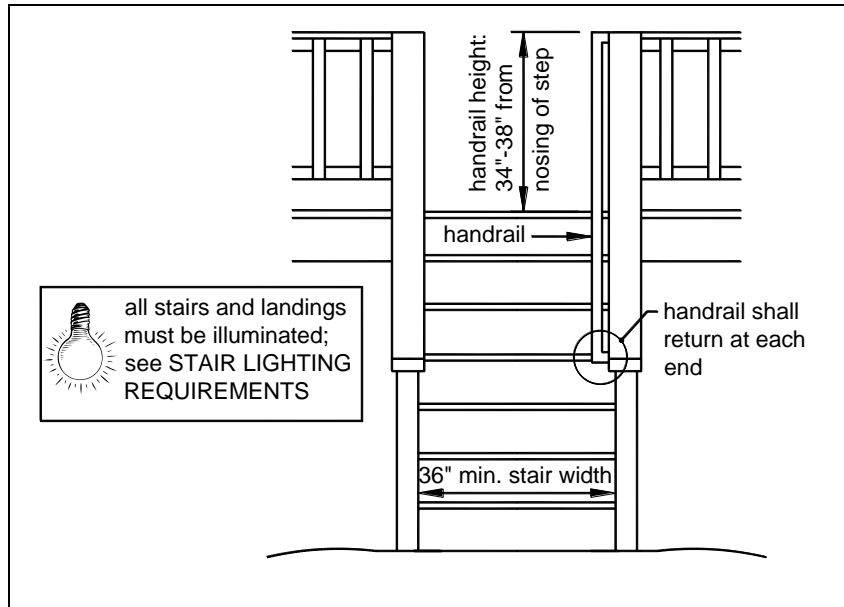


**FIGURE 39: HANDRAIL GRASPABILITY TYPES/GEOMETRY**

Handrails shall run continuously from a point directly over the lowest riser to a point directly over the highest riser and shall return to the guard at each end; see FIGURE 41. Handrails may be interrupted by guard posts only at a turn in the stair.



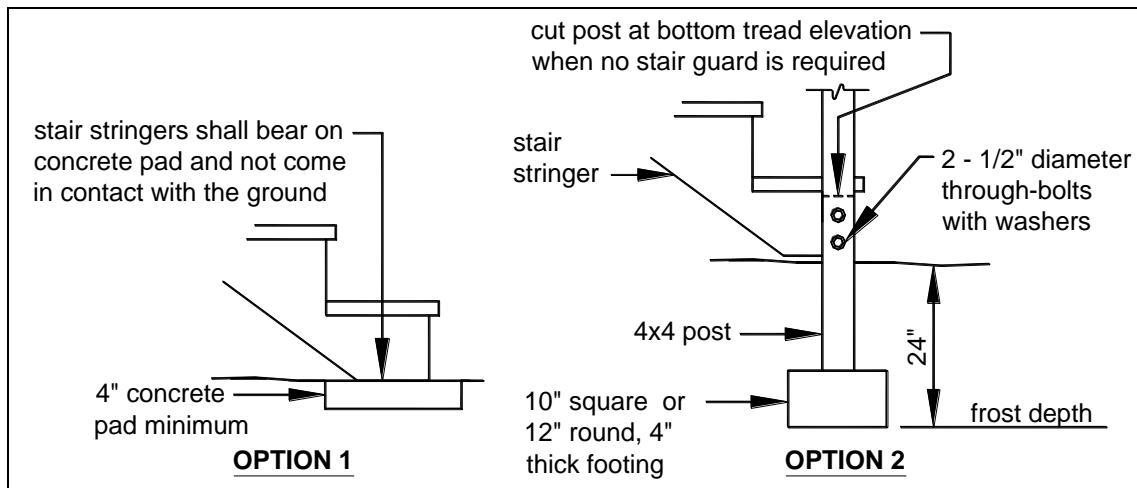
**FIGURE 40: HANDRAIL REQUIREMENTS**



**FIGURE 41: MISCELLANEOUS STAIR REQUIREMENTS**

**STAIR LIGHTING REQUIREMENTS:** Stairways shall have a light source located at the top landing such that all stairs and landings are illuminated. The light switch shall be operated from inside the house. However, motion detected or timed switches are acceptable.

**STAIR FOOTING REQUIREMENTS:** Where the stairway meets grade the stair stringers shall bear on a 4" concrete pad minimum or attach to 4x4 posts as shown in FIGURE 42. The pad shall be sized such that all stringers have complete bearing on concrete and do not come in contact with the ground.



**FIGURE 42: STAIR STRINGER BEARING AT GRADE**